

WHEEL LOADERS

W110 D | W130 D | W170 D | W190 D



Agricultural focus. Industrial productivity.

New Holland W110 D, W130 D, W170 D and new W190 D wheel loaders are designed to meet the needs of large scale farmers, agricultural contractors, composting operators and biogas farmers where absolute loading performance is critical. Developed from machines proven in the toughest quarries, 24-hour recycling plants and countless intensive industrial applications, New Holland wheel loaders deliver tough, versatile and reliable performance. The latest D series wheel loaders now deliver more, with an all-new, best-in-class cab for improved visibility and unrivalled levels of comfort in addition to a range of new features to improve productivity.

The new touchscreen colour display hosts features such as a new integrated payload scale, new fuel saving engine work modes, tyre pressure monitoring and hydraulic aggressiveness settings. The three new armrest mounted configurable short-cut buttons allow operators to tailor their set up, so they can quickly access their most frequently used functions. On the outside, parallel lift technology is now available as standard on all Z-bar models and is no longer exclusive to Tool Carrier machines. The upgraded lighting package features additional rear LED lights integrated into the grill to give an overall output of an impressive 43,000 lumen. Operator comfort and convenience aren't the only things that have been improved, service intervals have now doubled to 1000 hours, halving your service time and reducing maintenance costs by up to 20%. New Holland wheel loaders have always offered exceptional levels of strength, performance and reliability. Now they offer exceptional levels of comfort, versatility, technology and economy to make them the operator's first choice.

Two engine working modes

Best in class cab

Standard or Long Reach booms

Adjustable hydraulic responsiveness

Tool Carrier parallel linkage boom option on W110 D, W130 D & W170 D

Z-bar booms feature parallel lifting as standard

Fully integrated payload scale

Heavy duty or standard duty axles

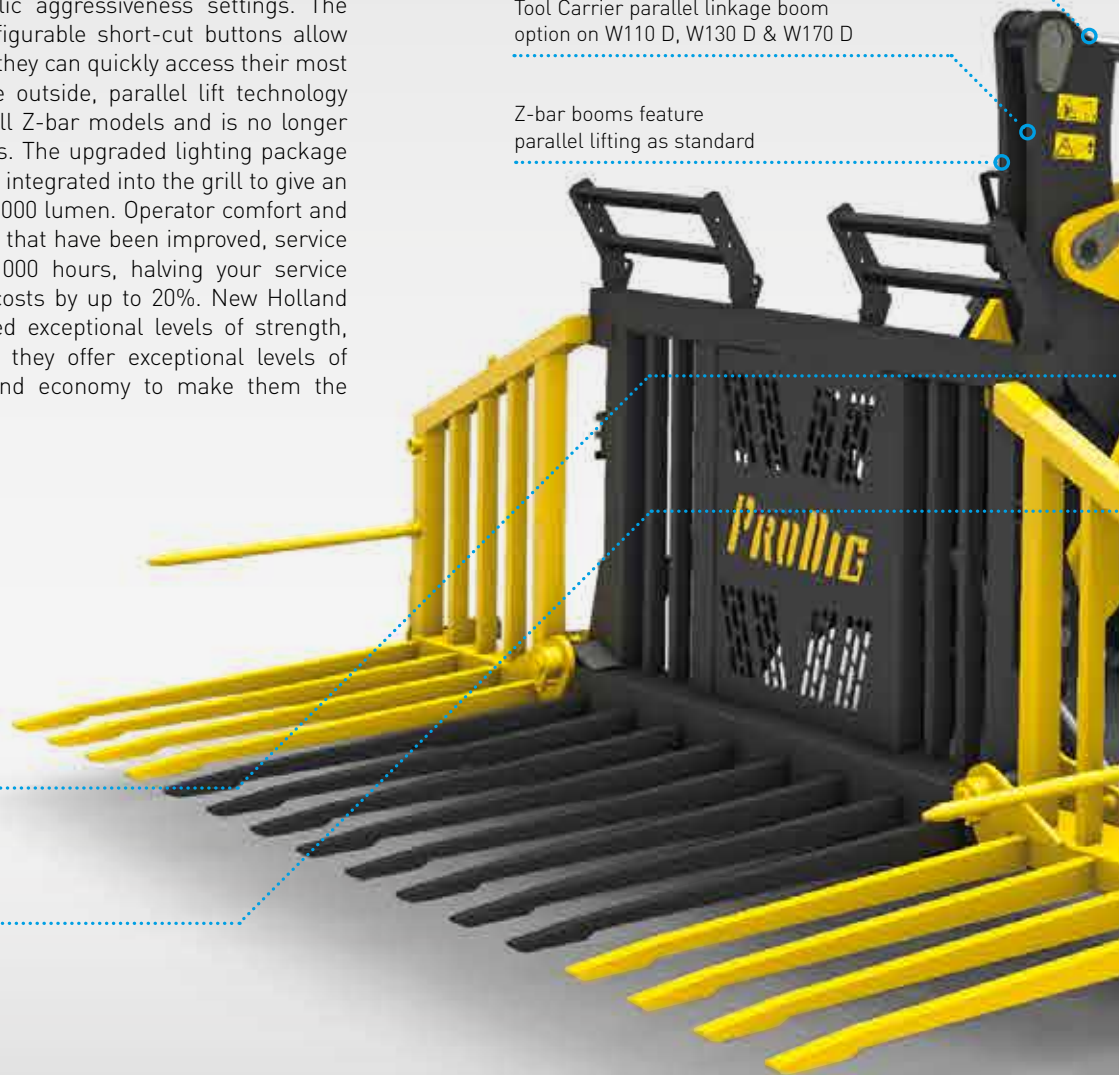



Models	Engine Power (hp)	Operating Weight Z-bar / LR / TC (kg)*	Tipping load straight Z-bar / LR / TC (kg)*
W110 D	142	11100 / 11190 / 11560	8870 / 7650 / 7260
W130 D	172	12850 / 12980 / 13380	10800 / 9190 / 8940
W170 D	195	14770 / 14970 / 15390	12640 / 10610 / 9890
W190 D	230	18200 / 18440 / -	14700 / 11790 / -

* weights quoted without Quick Coupler option

Efficiency without compromise.



ECOBBlue

HI-eSCR2

Powered by 4.5L and 6.7L NEF High Efficiency Selective Catalytic Reduction HI-eSCR 2 engines, New Holland W110 D, W130 D, W170 D and W190 D wheel loaders combine proven dependability and class leading economy. Compliant with Stage V emission regulations, the NEF power units have been co-developed with New Holland sister company FPT Industrial, the pioneer of common rail fuel injection and producer of SCR power units proven in agriculture, transport and industry for over 10 years. The latest ECOBlue and HI-eSCR 2 technology employs a newly developed electronic control unit that manages both the engine and the HI-eSCR exhaust to precisely match engine load, emissions and after-treatment. Using a dedicated closed loop system to continuously monitor NOx levels in the exhaust, HI-eSCR precisely monitors the flow of AdBlue. This will achieve more than 95% NOx conversion with minimised AdBlue usage. What's more, the HI-eSCR 2 system does not utilise a DPF or need to regenerate, so achieves a much lower maximum operation temperature, a critical factor when working with dry flammable material such as wood chips.



Optimum weight distribution

New Holland has engineered the D series wheel loader with the engine mounted far behind the rear axle, optimising the weight balance, eliminating the need to add extra "dead" weight. This approach also allows unhindered ground level access to the engine service points as there are no stacked radiators to get in the way. Due to the clean running characteristics of the power unit, engine oil change intervals are set at 1000 hours. Combined with class leading fuel economy, NEF power units are used across the range of New Holland tractors, combine harvesters and forage harvesters meaning unrivalled after-sales support.

Unique cooling package

- A key design feature of D series loaders is the positioning of the engine behind the rear axle, with a cooling 'cube' between the engine and transmission
- The programmable reversible fan option forces air through each of the five main radiators individually, ensuring each one benefits from a direct flow of cool air
- Hot air is not passed between each radiator, reducing the load on the cooling fan which in turn reduces power consumption

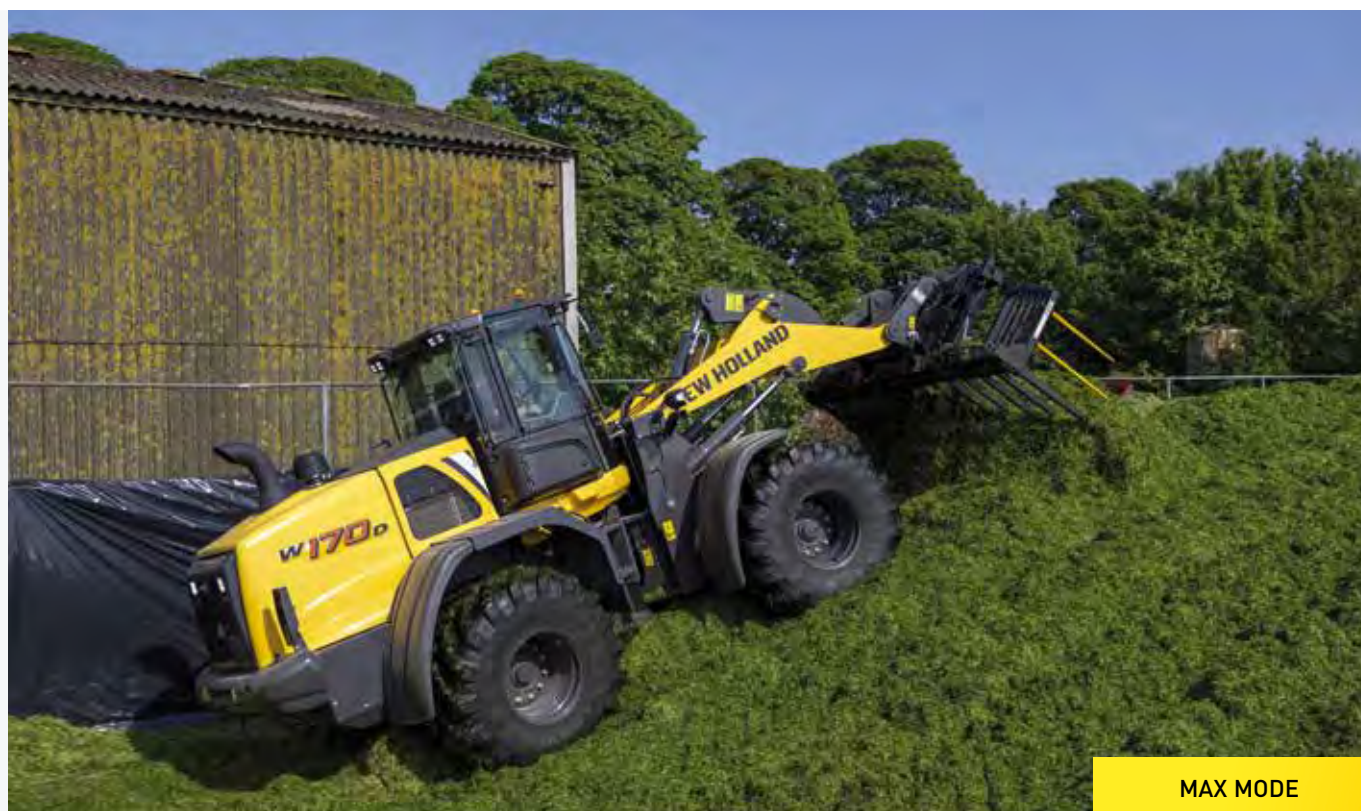

Selectable engine work modes

Choose from two different engine modes to tailor engine output to your requirements for maximum efficiency and fuel savings.

- **Max mode:** optimises the the engine power and transmission to deliver maximum power, torque and acceleration for aggressive pushing and climbing. Ideal for applications such as pushing silage
- **Smart mode:** manages the engine and transmission performance to optimise fuel efficiency, reducing fuel use by up to 10%. Smoother gearshifts and increased operator comfort make it ideal for applications such as grain and sugar beet loading



Proven durability in the harshest of conditions.

New Holland has engineered the D Series wheel loaders to suit re-handling of root crops, compost, farm yard manure, grain, woodchip and other bulk materials. D Series wheel loaders also have the traction to work in deep muck or work on a steep silage clamp. These machines are designed with maximum productivity in mind, and equipped with the performance to keep up with the highest output forage harvesters.

Heavy duty transmission

- A five-speed 40kph* Ecoshift PowerShift™ transmission is standard on W130 D, W170 D & W190 D models
- The torque convertor can lock above 2nd gear to ensure 100% of engine power is sent to the axles
- Incorporating a 'power-inch' function, the transmission delivers optimised pushing power whilst eliminating roll back
- The W110 D is available with a 40kph* four-speed PowerShift™ transmission with automatic or manual gear selection
- On all four models, the forward reverse shuttle can be operated via a steering column mounted lever or by forward / reverse buttons on the joystick
- To speed load cycles, releasing the drive pedal will bring the loader to a stop without the need to use the brakes. Even on an incline, there will be no roll back
- If the brake is pressed, full engine power will be diverted to the hydraulics for full loading performance

* 50kph with Michelin Mega X-bib 750/65R26, where homologation allows



Rear axle oscillation

- Rear axle oscillation is not compromised by the large 750/65R26 agricultural tyre option, allowing stability to be maintained while traversing large lumps of material encountered during grass silage and maize clamping

Heavy duty axles

- As standard, W170 D & W190 D wheel loaders are fitted with heavy duty axles with an automatic 100% locking front differential and a fully open differential in the rear axle
- The front differential can also be manually activated by a foot switch or configurable armrest button
- Heavy duty axles with front differential lock result in 20-30% less tyre wear and lower fuel consumption overall
- W110 D, W130 D & W170 D models can be equipped with standard axles front and rear featuring limited slip differentials, or with heavy duty axles with automatic 100% locking front differential



Transmission kickdown

- All models have a transmission 'kickdown' feature activated by a button on the joystick
- This feature provides quick access to a lower gear to optimise power when climbing or pushing



Durable rubber stops

- Durable replaceable rubber blocks absorb the impact of the chassis articulation points meeting at full steering lock
- Noise, shock and vibration is reduced as a result



Tyre pressure monitoring

- A sensor on each wheel monitors the tyre pressure
- The driver is alerted on the touchscreen if pressure drops below range
- Correct tyre pressure is critical to reducing fuel consumption and tyre wear and minimising downtime and operating costs



Ergonomic perfection.

Purpose designed for the D series wheel loaders, the new generation cab offers class leading all-round visibility, comfort and operator security. Fully FOPS and ROPS certified, the new cab features a curved, one-piece windscreen offering a clear and uninterrupted view of the loader arm, with an excellent view to the front as the boom is raised. Visibility over the shoulder, to the sides and extremities is excellent, allowing the operator to place the machine accurately and with confidence in confined areas. The seat mounted joystick control features a fully adjustable armrest, and the redesigned side console ensures all key functions are always within easy reach. Stay properly connected thanks to the Bluetooth radio with ceiling mounted microphone and remote AUX and USB sockets in the side console. The advanced ventilation package ensures the cab remains comfortable regardless of outside temperatures, with excellent filtration allowing operation in dusty environments. To further aid comfort, the cab is mounted on purpose designed viscous oil suspension blocks to reduce noise and vibration and results in noise levels as low as 68dB(A).



Luxury seat option

- Operators working over rough terrain, silage clamps and spending long hours in the cab can specify a deluxe seat with automatic weight adjustment, half leather trim, low frequency shock absorption system, headrest and heating



Excellent ventilation

- Thirteen adjustable vents keep you comfortable and the cab glass clear
- A grid defroster takes care of the rear window in cold conditions



Finishing touches

- Dual internal cab mirrors and front and rear sun blinds increase safety and help reduce blindspots
- Right side window can be locked fully open to allow easy communication with people on the ground



Keep it cool

- Optional 30 litre portable coolbox keeps your drinks and snacks cool all day



Cab filtration

- The cab filter cartridge combines high levels of filtration with generous capacity to allow extended periods between renewal
- There is a choice between the standard CAT2 HVAC or a CAT3 Activated carbon filter can be ordered separately through CNH parts
- The filtration system is linked to an advanced heating and air-conditioned ventilation package

Controls.

The D series wheel loaders have a new armrest and joystick design that has been developed to considerably reduce operator fatigue. The angle of the operators arm to the body has been carefully considered to minimise strain on the joints and not to compromise blood flow. Full seating support ensures good posture is maintained. Three new armrest mounted configurable short cut buttons make the operators preferred frequently used functions more easily accessible. The result? Less fatigue and benefits for the operator's long term health.



New seat mounted armrest

- Fully adjustable seat mounted armrest and arm cushion
- Armrest can slide horizontally independently of the seat for maximum comfort
- Armrest cushion can move vertically





New touchscreen dashboard display

- New touchscreen, 8inch LCD colour display provides the operator with a digital dashboard on the A pillar
- Tap and scroll through various menus to include machine information, service settings and reminders or even the operators manual
- Set a variety of working parameters such as starting gear, flow rates and engine modes
- When reverse is selected, the display will automatically show the rear camera view
- The display is anti-glare and automatically switches between day and night modes



Configured for you

- Three new configurable buttons on the armrest allow you to tailor your controls through the touchscreen
- Ergonomic position provides quick access to the most frequently used functions
- Configure different functions relative to different screen pages: home screen or payload screen
- Configurable functions include: diff lock engagement, camera, beacon, engine work mode, tare zero, new ticket



Spoiled for choice

- New joystick features FNR, auxiliary service and transmission kickdown functions as standard
- A 2nd auxiliary function can be specified on the joystick



Everything within easy reach

- New side console features a neat button cluster keeping everything within easy reach
- Grouped and colour coded, the buttons feature lights to indicate if the function is active
- Rubber lined storage trays, two cup holders, storage net, remote AUX jack & USB sockets and 12 volt power sockets are standard



Differential lock

- Differential lock is activated by a floor mounted electronic foot switch to the left of the brake pedal
- Large pedals are ergonomically positioned for brake and accelerator functions
- Alternatively, differential lock can be activated by one of the freely configurable buttons on the armrest

Raising the standard.

New Holland W110 D, W130 D, W170 D and W190 D wheel loaders are fitted as standard with the mighty Z-bar linkage boom, constructed from 45mm thick plate steel. The choice between Standard and Long Reach booms enables the machine to be specified to meet different handling priorities. On W110 D, W130 D & W170 D models, the high visibility Tool Carrier parallel lift boom option is now available.

Self levelling Z-bar linkage

In applications such as grain handling, composting and soil handling where digging and pushing performance as well as high breakout force are paramount, the Z-bar linkage is the natural choice. In addition, fewer moving parts simplify daily maintenance. Parallel lifting is now available as standard on Z-bar booms, so you get the best of both worlds, high breakout force with self levelling capability. Z-bar linkage loaders are offered with a choice of boom length:

- **Standard Boom**

In demanding agricultural and compost applications, the high strength standard boom is ideally suited to working with silage forks, grain pushers and heavy-duty buckets

- **Long Reach Boom**

The Long Reach boom increases dump heights by between 400 and 500mm. The longer boom is the ideal choice for re-handling duties to include intensive grainstore management, waste composting, vehicle loading and stockpiling work, but still with the exceptional strength of the Standard boom





Tool Carrier linkage

In applications that require high visibility and self levelling capability, such as pallet and bale handling using forks and specialist attachments, the Tool Carrier linkage is the best choice and comes as standard with the hydraulic quick coupler for attachment versatility. Tool Carrier linkage option is available on W110 D, W130 D & W170 D models.

Watching your weight.

Whether you're feeding a biogas digester or a herd of cattle, loading grain out of the store or stockpiling soil or gravel, it's always beneficial to accurately know and record the quantities of material you're dealing with, especially if you're a contractor getting paid by the ton. New Holland D series loaders are now available with a fully integrated factory fit payload scale to remove the guesswork out of any loading job and extract the maximum return on your investment.



Automatic boom functions

- Lift to a predetermined height
- Return to a pre-set dig level
- Raise the boom to a set height for travel / cycling between load and dump
- Auto Glide boom suspension can be specified



Hydraulic flow on demand

- Closed centre load sensing hydraulics are standard, the W170 D and W190 D benefitting from tandem pumps for increased capacity
- A key element of the New Holland design is efficiency, the pumps delivering the required hydraulic flow upon demand
- When the brake pedal is pressed, full engine power is made available to the hydraulics but the system will only demand extra power as required for the task, adjusting flow in accordance with demands, for fast boom raise/lower or attachment crowd/dump

Model		Hydraulic pump capacity
W110 D	(l/min)	134
W130 D	(l/min)	169
W170 D	(l/min)	206
W190 D	(l/min)	236

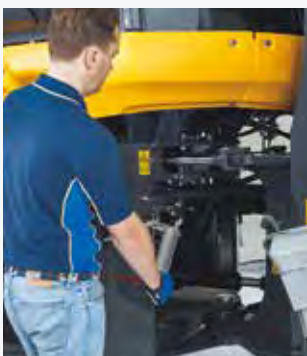

Centralised grease points

- Where possible, all grease points are grouped together
- The optional auto lubrication system ensures regular and metered lubrication to reduce whole life operating costs
- Automatic lubrication system features an in-cab switch to activate a manual greasing cycle



Automatic payload scale

The automatic payload scale utilises the new touchscreen display to accurately weigh material as it is being loaded and features a host of functions for easy record keeping and management such as stored customers, vehicle registrations, material type and buckets. In addition, all relevant data can be entered on the touchscreen and printed on a ticket when the load is complete.

- Easy to calibrate
- 98% + accuracy
- Target loading mode
- Auto loading mode
- Configurable armrest button functionality
- Slope correction
- Hydraulic oil temperature compensation
- Z-bar & Tool Carrier compatible

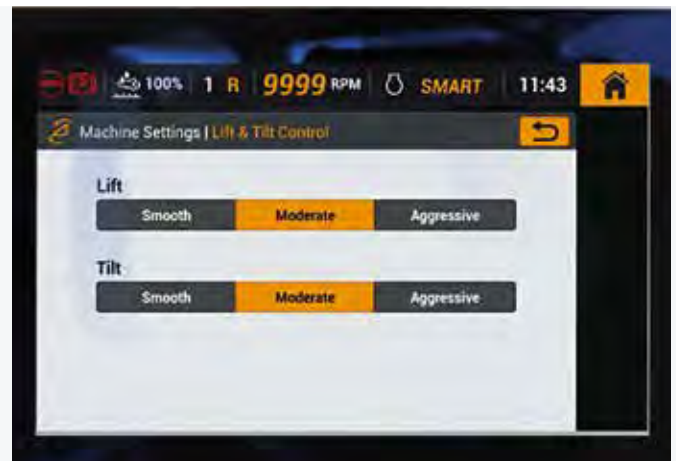

Tailored hydraulic response

Accessed via the touchscreen display, the hydraulic responsiveness of the lift and crowd functions, auxiliary hydraulics and joystick steering can be tailored to the application or operators experience.

- **Smooth:** more control for precision applications or novice operators
- **Moderate:** normal level of responsiveness
- **Aggressive:** sharper and more responsive control for fast operation and experienced drivers



Spend time saving money.

A key benefit of the new Stage V compliant D series loaders is the vastly extended service intervals. At New Holland we know a vital machine such as a wheel loader has to be kept in top condition as it is often subject to a busy year round workload and can accumulate a high number of hours in a short period of time. In response to this we have doubled the engine service intervals from 500 to 1000 hours, and similarly increased the service intervals of other fluids and filters.

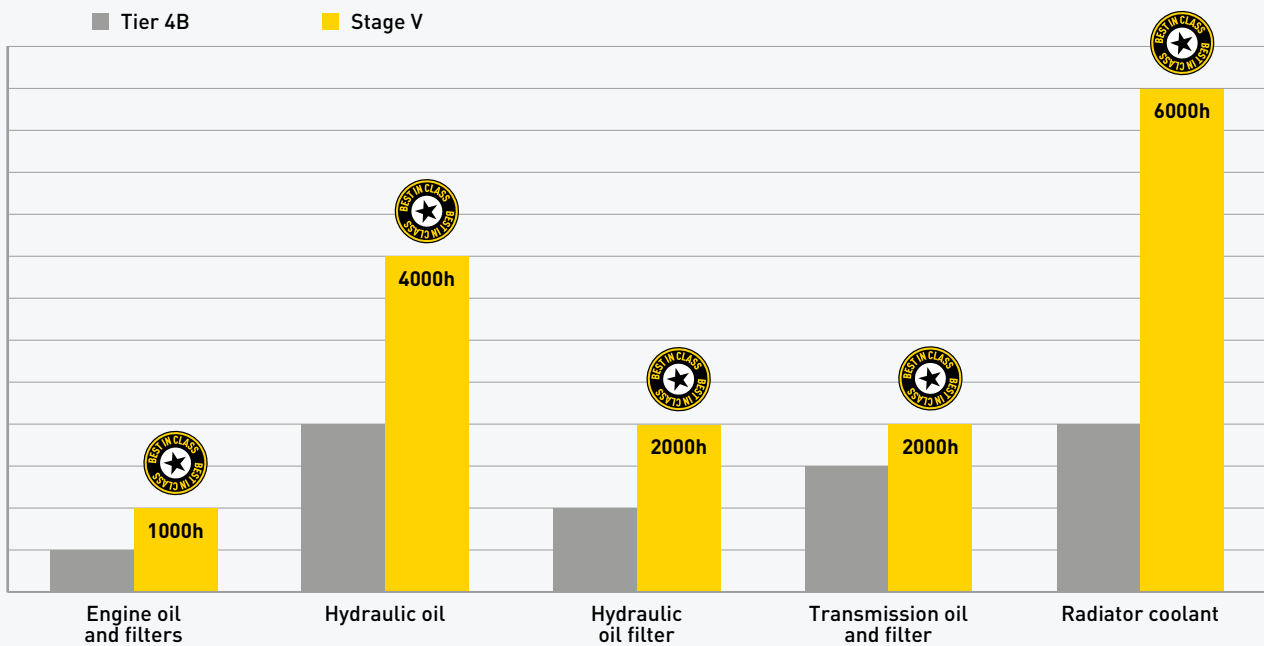

The figures speak for themselves, the time saved by not having to stop and service allows you to get through entire seasons uninterrupted, what's more, you can save up to 20% on maintenance costs, a significant saving over the whole life of the machine. When combined with the fuel saving benefits of the new Smart engine work mode, New Holland D series wheel loaders guarantee low Total Cost of Ownership and keep you working for longer.



Easy and fast service and maintenance

All key service items can be reached from ground level, the one-piece engine hood lifting and closing electronically for simplified access. The cube cooling pack is designed to be easy to clean. The cab filter can be removed, cleaned and replaced with no need to climb steps or fiddle with difficult fasteners. A further boost is the optional centralised greasing system. New Holland D series wheel loaders are engineered for performance, longevity and reduced whole life operating costs.



- One piece engine hood features electric opening on W130 D, W170 D and W190 D models



- Hood raise switch, battery kill switch and remote battery terminals are grouped at the rear



- Easy access to each of the individual radiators allows easy routine cleaning



- Ground level service access makes jobs simpler, faster and safer



- For security, the fuel tank and AdBlue tank are accessed only by raising the engine hood

Productivity enhancing options.



Tyres

- New Holland offers a wide choice of factory fit tyres for work over paved surfaces or for use over soft ground or working on steep sided silage clamps
- Wheel fender widths are available to match the selected wheel and tyre package

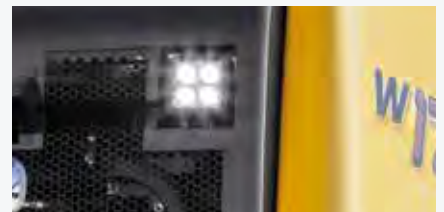

Quick coupler

- Attachment versatility and timeliness is guaranteed thanks to the heavy duty hydraulic quick coupler which is compatible with a wide variety of attachments
- Visible indicators show the operator the status of the locking pins

Joystick steering JSS

- The JSS system employs a joystick on the left armrest to control the steering function of the wheel loader
- Operator fatigue is greatly reduced and machine productivity is increased in repetitive-cycle operations such as truck loading and compost recycling, which typically follow a repetitive V pattern

LED lighting

- Enhance safety and turn night into day with up to ten high intensity LED cab work lights
- Two additional LED hood lights illuminate the rear camera view to bring total light output to 43,000 lumens
- New egress lighting illuminates your path once the machine is switched off

Models	W110 D	W130 D	W170 D	W190 D
Engine				
FPT Industrial engine	NEF N45	NEF N67	NEF N67	NEF N67
Displacement (l)	4.5	6.7	6.7	6.7
Cylinders	4	6	6	6
Aspiration	Turbocharger with air-to-air cooling			
No EGR valve is used	Only fresh air is taken for combustion and no extra cooling system is needed			
Injection	Common Rail Multiple Injection			
After Treatment System	HI-eSCR 2 (DOC + SCRoF)			
Emissions level	Compliant with EU Stage V			
Max power [kW/hp(CV)]	106/142 @ 1800rpm	128/172 @ 1800rpm	145/195 @ 2000rpm	172/230 @ 1800rpm
Max torque (Nm)	608 @ 1600rpm	730 @ 1600rpm	950 @ 1300rpm	1184 @ 1300rpm
Transmission				
Gearbox	PowerShift™ 4 speeds	PowerShift™ 5 speeds "Ecoshift"		
Clutch	Torque converter	Torque converter with: - Automatic lock-up engagement from 2nd up to 5th gear - Power inch: proportional declutching depending on braking intensity		
Forward (km/h)	6-11-22-36	7-13-20-31-45	7-13-19-30-40	6.6-11-17-26-40
Reverse (km/h)	6.4-12-23	7-14-32	8-14-31	7-12-28
Axles and differential				
Rear axle total oscillation (°)	24			
Heavy duty ZF axles	Open differentials and automatic 100% lock system on the front differential 100% tractive effort always, no wheel slip, less tyre wear			
Standard ZF axles	Limited slip differentials front and rear 73% tractive effort on slippery ground			-
Tyres				
Standard tyre size	17.5R25	20.5R25	20.5R25	23.5R25
Brakes				
Service brake	Maintenance free, self-adjusting wet 4-wheel disc brakes			
Brake disc area (m ² /hub)	0.39	0.39	0.39	0.39
Parking brake	With the negative brake all four wheels are automatically stopped when the engine is stopped			
Parking disc brake area (cm ²)	58	58	82	82
Hydraulics				
Valves	Rexroth Closed-center, Load sensing hydraulic system Main valve with 3 sections			
Steering	The steering orbitrol hydraulically is actuated with priority valve			
Automatic functions	Bucket Return-to-dig, Boom Return-to-travel, Boom Auto-lift, Parallel lift			
Control type	Pilot with proportional solenoid valves controlled by electro-hydraulic single joystick or single-axis 3 levers			
Type of pump (l/min)	Tandem Variable displacement pump			
	134 @ 2000rpm	169 @ 2000rpm	206 @ 2000rpm	236 @ 2000rpm
Auxiliary hydraulic circuit				
Max flow (l/min)	134	169	206	236
Max pressure (bar)	249-255	249-255	249-255	249-255
Service capacities				
Fuel tank (l)	189	248	246	288
AdBlue tank, permanently heated by engine coolant (l)	41.3	41.3	41.3	41.3
Cooling system (l)	22	27	28	30
Engine oil (l)	12	13	13	13
Hydraulic oil tank (l)	57	91	91	91
Total hydraulic system oil (l)	114	148	180	180
Front and Rear Axles (l)	22 + 22	22 + 22	35 + 35	40 + 40
Transmission oil (l)	19	27	34	34
Cab protection				
Protection against falling objects (FOPS)	ISO EN3449			
Protection against roll over (ROPS)	ISO EN13510			
Noise and vibration				
In the cab - LpA (ISO 6595/6396/3744) [dB(A)]	68	68	68	68
Outside - LwA (SAE J88 SEP80) [dB(A)]	102	104	103	104
Vibrations	Operator's seat meets the criteria of ISO 7096:2000 The vibrations transmitted do not exceed 0.5m/s ²			
Electrical system				
System voltage (V)	24	24	24	24
Batteries	2 x 12V	2 x 12V	2 x 12V	2 x 12V
Alternator - capacity (Amps)	70	120	120	120

- Not available

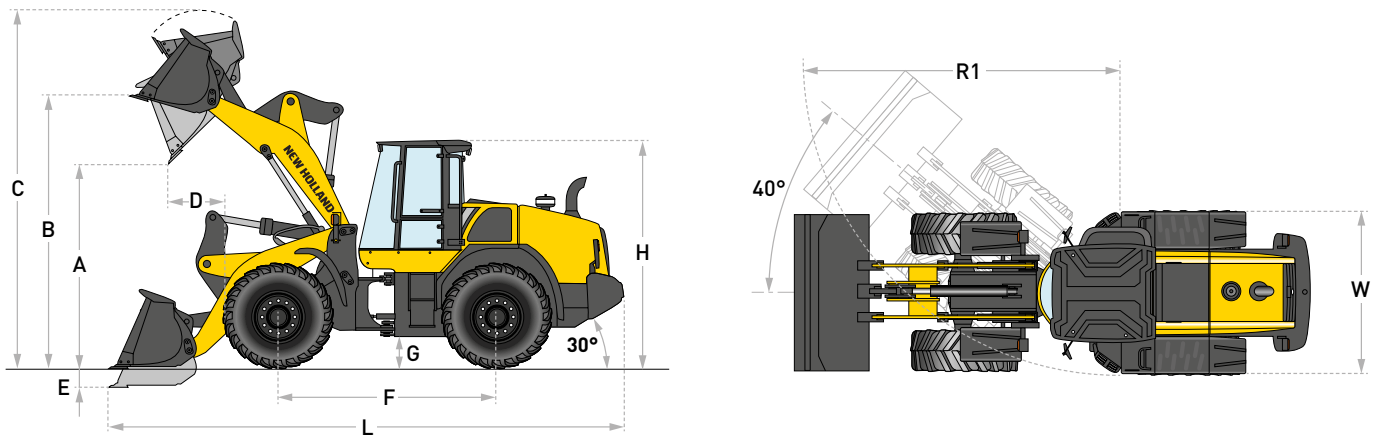

Dimensions

Z-bar

Long Reach

Tool Carrier

Bucket mount (with bolt-on cutting edge)	Direct	QC	Direct	QC	B.O.E.	Teeth+Segm
Std GP Bucket Rated Capacity (m³)	2.1	1.8	1.9	1.8	1.8	1.7
Bucket Capacity at 110% Fill Factor (m³)	2.3	1.9	2.1	1.9	1.9	1.9
Bucket overall width (mm)	2500	2440	2500	2440	2440	2440
Bucket weight (kg)	850	1055	815	1050	1050	1080
A - Dump height at 45° @ full boom height (mm)	2610	2480	3040	2929	2430	2360
B - Bucket hinge pin height (mm)	3610	3610	3990	3980	3750	3750
C - Overall height (mm)	4740	4740	5060	5120	4930	4930
D - Bucket reach at full boom height (mm)	1110	1070	1040	1130	1110	1180
E - Digging depth (mm)	80	100	110	140	190	200
F - Wheelbase (mm)	2750	2750	2750	2750	2750	2750
G - Ground clearance (mm)	340	340	340	340	340	340
H - Cab roof height (mm)	3270	3270	3270	3270	3270	3270
L - Overall length on ground (with bucket) (mm)	6840	6930	7110	7270	7120	7220
Overall length on ground (w/o bucket) (mm)	5770	5770	6090	6090	5730	5730
W - Overall vehicle width (without bucket) (mm)	2450	2450	2450	2450	2450	2450
Departure angle (°)	30	30	30	30	30	30
R1 - Turning radius (at outer wheel) (mm)	5000	5000	5000	5000	5000	5000
Turning radius (at bucket corner) (mm)	5530	5530	5670	5670	5530	5570
Full steering angle (°)	40	40	40	40	40	40
Bucket rollback @ boom carry position (°)	44	50	46	51	52	52
Bucket dump @ maximum boom height (°)	55	45	51	40	57	57
Machine operating weight (L3 tyres) (kg)	11100	11300	11190	11430	11560	11590

Loader performance

Z-bar

Long Reach

Tool Carrier

Bucket mount (with bolt-on cutting edge)	Direct	QC	Direct	QC	B.O.E.	Teeth+Segm
Bucket payload (kg)	3895	3735	3350	3170	3175	3170
Maximum material density (t/m³)	1.85	2.07	1.76	1.76	1.76	1.86
Tipping load straight (kg)	8870	8530	7650	7280	7260	7250
Tipping load full turn (kg)	7790	7470	6700	6340	6350	6340
Bucket break-out force (daN)	7453	6884	7973	6884	7894	8090
Loader speed						
Lift (full load) (sec)	5.4	5.4	5.4	5.4	5.4	5.4
Dump (full load) (sec)	1.2	1.2	1.2	1.2	1.2	1.2
Lowering (empty power down) (sec)	3.9	3.9	3.9	3.9	3.9	3.9
Lowering (empty float down) (sec)	3.9	3.9	3.9	3.9	3.9	3.9

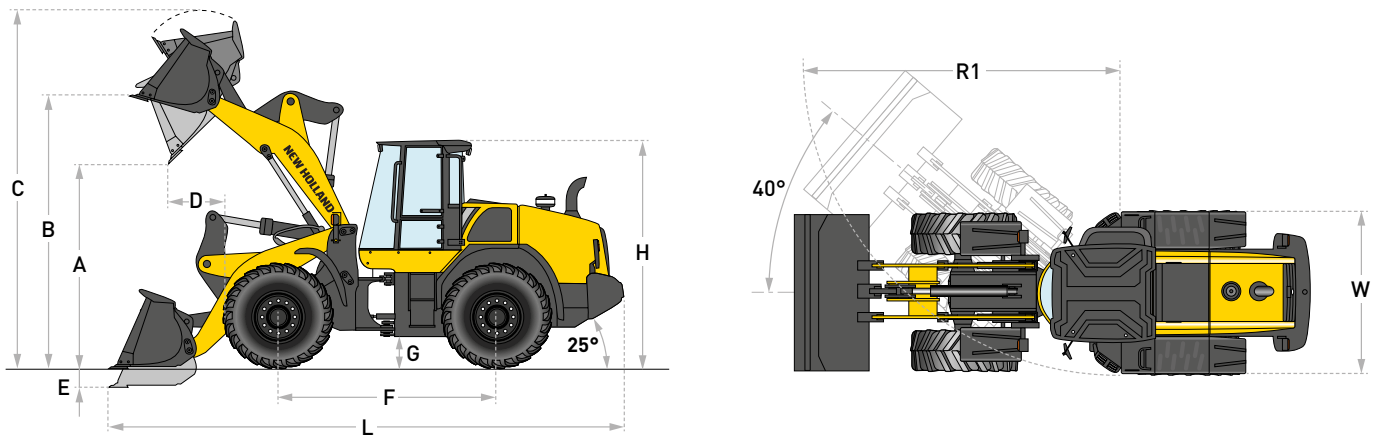

Dimensions

Z-bar

Long Reach

Tool Carrier

Bucket mount (with bolt-on cutting edge)	Direct	QC	Direct	QC	B.O.E.	Teeth+Segm
Std GP Bucket Rated Capacity (m³)	2.4	2.0	2.2	2.0	2.0	2.0
Bucket Capacity at 110% Fill Factor (m³)	2.6	2.2	2.4	2.2	2.2	2.2
Bucket overall width (mm)	2490	2490	2490	2490	2490	2540
Bucket weight (kg)	925	1375	880	1375	1255	1285
A - Dump height at 45° @ full boom height (mm)	2750	2700	3260	3210	2570	2490
B - Bucket hinge pin height (mm)	3830	3830	4260	4240	3960	3960
C - Overall height (mm)	5040	5050	5460	5460	5230	5230
D - Bucket reach at full boom height (mm)	2080	1100	1000	1210	1100	1170
E - Digging depth (mm)	90	90	90	90	180	180
F - Wheelbase (mm)	2900	2900	2900	2900	2900	2900
G - Ground clearance (mm)	390	390	390	390	390	390
H - Cab roof height (mm)	3380	3380	3380	3380	3380	3380
L - Overall length on ground (with bucket) (mm)	7470	7630	7870	8030	7780	7880
Overall length on ground (w/o bucket) (mm)	6280	6280	6690	6690	6200	6200
W - Overall vehicle width (without bucket) (mm)	2480	2480	2480	2480	2480	2480
Departure angle (°)	25	25	25	25	25	25
R1 - Turning radius (at outer wheel) (mm)	5220	5220	5220	5220	5220	5220
Turning radius (at bucket corner) (mm)	5760	5750	5920	5940	5720	5770
Full steering angle (°)	40	40	40	40	40	40
Bucket rollback @ boom carry position (°)	45	50	46	51	59	59
Bucket dump @ maximum boom height (°)	51	41	46	35	50	50
Machine operating weight (L3 tyres) (kg)	12850	13300	12980	13480	13380	13410

Loader performance

Z-bar

Long Reach

Tool Carrier

Bucket mount (with bolt-on cutting edge)	Direct	QC	Direct	QC	B.O.E.	Teeth+Segm
Bucket payload (kg)	4700	4440	3980	3685	3865	3860
Maximum material density (t/m³)	1.95	2.22	1.80	1.84	1.93	1.93
Tipping load straight (kg)	10800	10270	9190	8580	8940	8930
Tipping load full turn (kg)	9400	8880	7960	7370	7730	7720
Bucket break-out force (daN)	9905	9267	11327	9297	10238	10434
Loader speed						
Lift (full load) (sec)	6.3	6.3	6.3	6.3	6.3	6.3
Dump (full load) (sec)	1.2	1.2	1.2	1.2	1.2	1.2
Lowering (empty power down) (sec)	4.4	4.4	4.4	4.4	4.4	4.4
Lowering (empty float down) (sec)	4.8	4.8	4.8	4.8	4.8	4.8

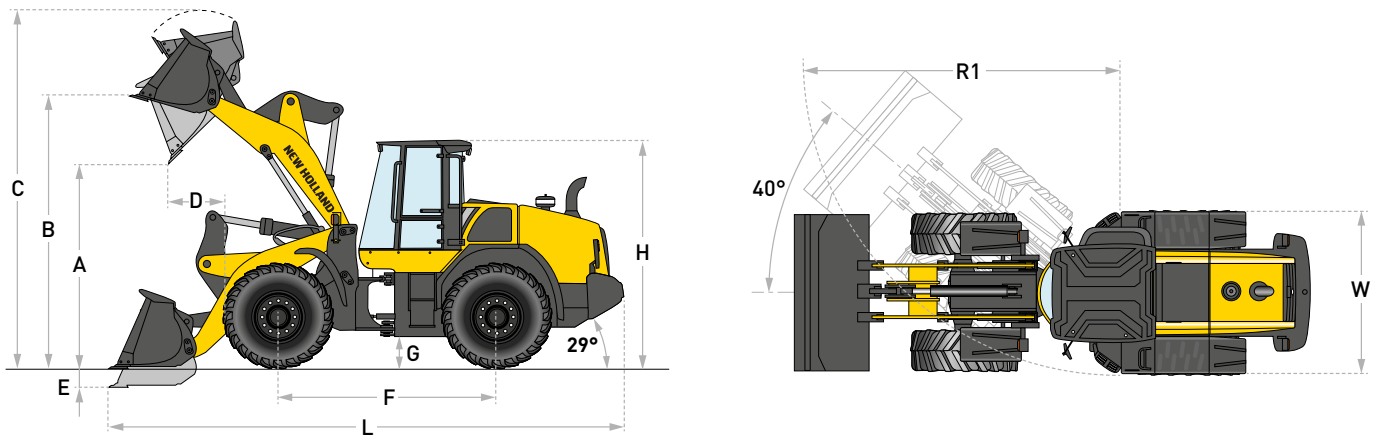

Dimensions

		Z-bar		Long Reach		Tool Carrier	
		Direct	QC	Direct	QC	B.O.E.	Teeth+Segm
Bucket mount (with bolt-on cutting edge)							
Std GP Bucket Rated Capacity	(m³)	2.8	2.7	2.8	2.7	2.7	2.7
Bucket Capacity at 110% Fill Factor	(m³)	3.1	3.0	3.1	3.0	3.0	2.9
Bucket overall width	(mm)	2710	2690	2710	2690	2490	2510
Bucket weight	(kg)	1220	1705	1220	1705	1634	1693
A - Dump height at 45° @ full boom height	(mm)	2920	2730	3330	3130	2800	2690
B - Bucket hinge pin height	(mm)	3979	3980	4370	4370	4160	4160
C - Overall height	(mm)	5320	5530	5910	5930	5580	5580
D - Bucket reach at full boom height	(mm)	1120	1170	1130	1170	1160	1250
E - Digging depth	(mm)	80	70	80	80	120	140
F - Wheelbase	(mm)	3250	3250	3250	3250	3250	3250
G - Ground clearance	(mm)	380	380	380	380	380	380
H - Cab roof height	(mm)	3380	3380	3380	3380	3380	3380
L - Overall length on ground (with bucket)	(mm)	7650	7840	8000	8200	6520	6520
Overall length on ground (w/o bucket)	(mm)	6530	6530	6850	6850	5750	5750
W - Overall vehicle width (without bucket)	(mm)	2560	2560	2560	2560	8000	8140
Departure angle	(°)	29	29	29	29	29	29
R1 - Turning radius (at outer wheel)	(mm)	5750	5750	5750	5750	5750	5750
Turning radius (at bucket corner)	(mm)	6320	6410	6520	6590	6410	6460
Full steering angle	(°)	40	40	40	40	40	40
Bucket rollback @ boom carry position	(°)	44	38	43	37	61	61
Bucket dump @ maximum boom height	(°)	50	51	50	51	47	47
Machine operating weight (L3 tyres)	(kg)	14770	15290	14970	15490	15390	15390

Loader performance

		Z-bar		Long Reach		Tool Carrier	
		Direct	QC	Direct	QC	B.O.E.	Teeth+Segm
Bucket mount (with bolt-on cutting edge)							
Bucket payload	(kg)	5495	4765	4580	3985	4270	4230
Maximum material density	(t/m³)	1.96	1.76	1.63	1.47	1.58	1.56
Tipping load straight	(kg)	12640	11040	10610	9300	9890	9820
Tipping load full turn	(kg)	10990	9530	9160	7970	8540	8460
Bucket break-out force	(daN)	14318	11896	14259	11758	11709	12003
Loader speed							
Lift (full load)	(sec)	5.2	5.2	5.2	5.2	5.2	5.2
Dump (full load)	(sec)	1.2	1.2	1.2	1.2	1.2	1.2
Lowering (empty power down)	(sec)	2.5	2.5	2.5	2.5	2.5	2.5
Lowering (empty float down)	(sec)	2.4	2.4	2.4	2.4	2.4	2.4

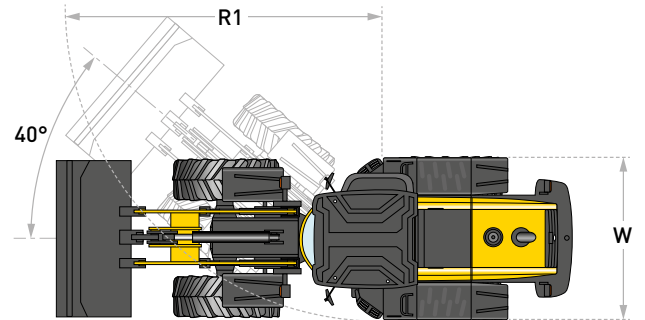
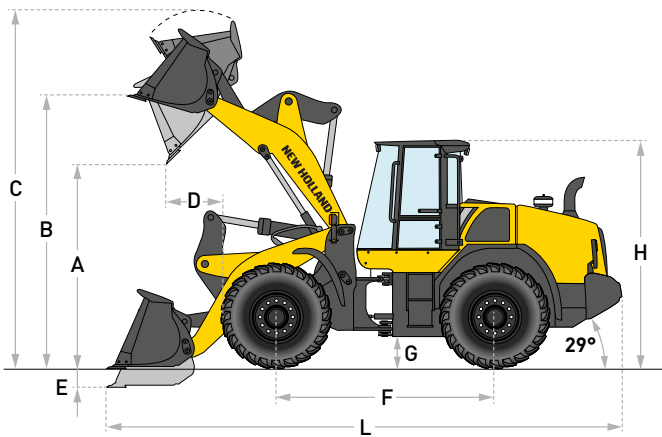

Dimensions

Z-bar

Long Reach

		Direct	Direct	Direct	Direct
Bucket mount (with bolt-on cutting edge)					
Std GP Bucket Rated Capacity	(m ³)	3.4	3.2	3.2	2.8
Bucket Capacity at 110% Fill Factor	(m ³)	3.8	3.5	3.5	3.1
Bucket overall width	(mm)	2950	2950	2950	2950
Bucket weight	(kg)	1570	1540	1540	1390
A - Dump height at 45° @ full boom height	(mm)	2940	2960	3390	3510
B - Bucket hinge pin height	(mm)	4120	4120	4560	4560
C - Overall height	(mm)	5490	5450	5890	5740
D - Bucket reach at full boom height	(mm)	1160	1140	1250	1140
E - Digging depth	(mm)	70	70	140	130
F - Wheelbase	(mm)	3340	3340	3340	3340
G - Ground clearance	(mm)	420	420	420	420
H - Cab roof height	(mm)	3460	3460	3460	3460
L - Overall length on ground (with bucket)	(mm)	8080	8050	8530	8360
Overall length on ground (w/o bucket)	(mm)	6780	6780	7240	7240
W - Overall vehicle width (without bucket)	(mm)	2830	2830	2830	2830
Departure angle	(°)	29	29	29	29
R1 - Turning radius (at outer wheel)	(mm)	6030	6030	6030	6030
Turning radius (at bucket corner)	(mm)	6630	6620	6870	6810
Full steering angle	(°)	40	40	40	40
Bucket rollback @ boom carry position	(°)	45	45	43	43
Bucket dump @ maximum boom height	(°)	55	55	49	49
Machine operating weight (L3 tyres)	(kg)	18200	18170	18440	18280

Loader performance

Z-bar

Long Reach

		Direct	Direct	Direct	Direct
Bucket mount (with bolt-on cutting edge)					
Bucket payload	(kg)	6390	6405	5080	5185
Maximum material density	(t/m ³)	1.87	2.00	1.58	1.85
Tipping load straight	(kg)	14670	14700	11750	11790
Tipping load full turn	(kg)	12780	12810	10160	10370
Bucket break-out force	(daN)	14749	15142	15396	17672
Loader speed					
Lift (full load)	(sec)	6.2	6.2	6.2	6.2
Dump (full load)	(sec)	1.2	1.2	1.2	1.2
Lowering (empty power down)	(sec)	2.9	2.9	2.9	2.9
Lowering (empty float down)	(sec)	2.5	2.5	2.5	2.5

New Holland Top Service: customer support and customer information.



Top Availability

If you need information, or have an out of hours question, ring our toll-free number*. All day, every day, we are just a call away.



Top Speed

Express parts delivery: when you need it, where you need it!



Top Priority

Fast-track solution during the season: because your harvest can't wait!



Top Satisfaction

We drive and track the solution you need, keeping you informed: until you are 100% satisfied!



For more details, ask your New Holland dealer!

* Calls to the Top Service team are free from landlines in the United Kingdom and Republic of Ireland. UK-based mobile calls are also free, but Republic of Ireland mobile users should call 01 2421881 and this will be charged at your standard network rate.

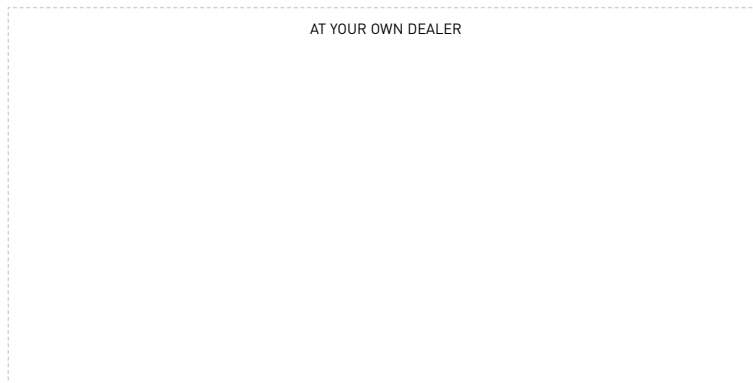

www.newholland.com/uk - www.newholland.com/ie

